

# POWERWALKER INVERTER1-2K



## User Manual

EN

## Important Safety Information

Before installing PowerWalker Inverter 1000/2000VA, please read the following information carefully and save this manual for further reference. Disregard of these safety notes may endanger life or health, as well as the function of the equipment. Special attention must be paid to the CAUTION and WARNING statements in this manual.

EN

### **CAUTION**

1. To reduce risk of injury, charge ONLY lead-acid type rechargeable batteries. Other types of batteries may cause damage and injury.
2. DO NOT operate the PowerWalker Inverter if it has been dropped or damaged in any way.
3. DO NOT expose PowerWalker Inverter to rain, snow or liquids of any type. PowerWalker Inverter is designed for indoor installation only.
4. NEVER charge a frozen battery.
5. DO NOT obstruct the ventilation openings.
6. Risk of electric shock Heat-sinks are live. Disconnect the AC sources and the DC source from this unit before servicing.
7. Risk of electric shock.This unit receives power from more than one source. Disconnect the AC sources and the DC source from this unit before servicing.
8. Do not remove cover. No user serviceable parts inside. Refer servicing to qualified service personnel.
9. The sum of the leakage current of the PowerWalker INVERTER and the connected equipment should not exceed 3.5mA.
10. Risk of explosion if battery is incorrectly connected or replaced.

### **WARNING**

1. Provide adequate ventilation from the battery compartment. The battery enclosure should be designed to prevent accumulation and concentration of hydrogen gas at the top of the compartment.
2. Input/output AC wiring and battery cables must be rated for 75°C or higher. Using cables diameter, please refer to appendix A, according to different models. The inner diameter of the copper ring terminal which is used to connect battery cables to PowerWalker Inverter DC terminals should be no less than 6mm.
3. For battery installation and maintenance: read the battery manufacturer's installation and maintenance instructions prior to operating.

### **PERSONAL PRECAUTIONS**

1. Have plenty of fresh water and soap nearby in case battery acid contacts skin, clothing, or eyes.
2. Avoid touching eyes while working near batteries.
3. NEVER smoke or allow a spark or flame in the near vicinity of a battery.
4. Remove personal metal items such as rings, bracelets, necklaces, and watches while working with batteries. Batteries can produce short circuit current high enough to make metal melt, and can cause severe burns.
5. If a remote or automatic generator start system is used, disable the automatic starting circuit or disconnect the generator to prevent accident during servicing.

Thanks for purchasing the PowerWalker Inverter 1000/2000VA. Properly used, this product will give you many years of reliable service.

The PowerWalker Inverter series is an electronic product that has been designed and built to take low DC voltage power from batteries and convert it to standard AC power like the current you have at home.

EN

The PowerWalker Inverter series is a DC-to-AC with auto line-to-battery transfer and integrated charging system,

PowerWalker Inverter series, powers from AC power and DC source, serving as an extended run UPS. When AC cable is connected to a wall socket, utility power goes to connected equipment(s) and/or charges the battery set via charging system. In UPS mode, the PowerWalker Inverter series automatically converts battery energy into AC power for backing up the connected devices.

## Features:

- Super efficient, DC to AC conversion, minimizing charging losses
- Input voltage range selection option
- Fully automatic start operation
- High frequency technology
- Compact size and light weight
- Provides critical overload protection
- Eco-friendly & non-polluting (green device)
- Advanced technology optimizes battery life

## Operation & Installation

### Front Panel Controls and LED Indicators

Shown below are the controls and indicator lights on the front panel of PowerWalker Inverter series.

EN

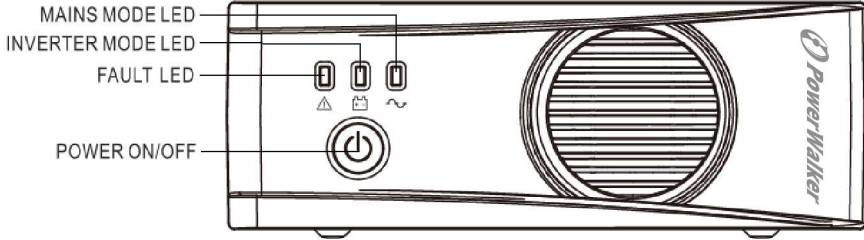

### Rear Panel & Output Description

Shown below are the components on the rear panel of PowerWalker Inverter series.

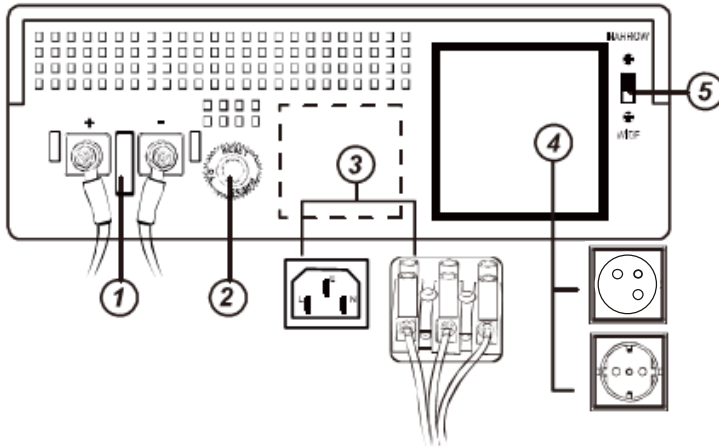

1. DC Input Connector (Battery Terminal)
2. Input Protector
3. AC Input or IEC Inlet
4. Output Receptacle(s)
5. Input Voltage Range Selector: Input voltage range is defined in specification chapter, and output voltage is the same as input voltage in 'mains' mode.
  - A. Select '**Narrow**' setting for general electrical appliance such as tube light, energy saving lamp, TV, Juicer & mixer etc, but it is not suitable to meet high-power motor or inductive

load ,such as the fridge of 1KW ,the motor of 800W, air cooler ,PC (having risk of rebooting) and so on. In this mode, the PowerWalker Inverter series operating voltage, in 'mains' mode, is within 170~280Vac with the same output voltage. The line sensitivity is higher.

- B. Select "**Wide**" setting to save energy. In this mode the operating range of voltage for the PowerWalker Inverter is 90-280Vac, hence the output voltage will be the same as the MAINS input voltage. The PowerWalker Inverter unit in this mode has a lower sensitivity. You can connect and use only for some special load, such as lamp, fan.

## Battery Connection

**Step 1-** Pinch the bottom of DC input cover and Open it.

**Step 2-** Follow battery polarity guide located near battery terminal. Place the battery cable ring terminal over PowerWalker Inverter's battery terminal. Tighten the M5 nut. Do not place anything between the flat part of battery terminal and the battery cable ring terminal, since overheating may occur.

**Caution!** DO NOT place anything between battery cable ring terminals and battery terminals. The terminal stud is not designed to carry current. Apply Anti-oxidant paste to terminals after terminals have been torqued.

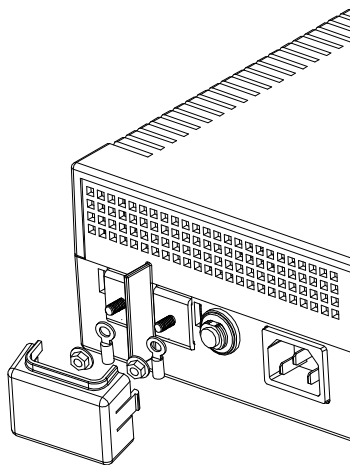

Battery Cable Connection to PowerWalker Inverter 1000/2000VA

### Step 3- Connect battery cables to your batteries

The battery must be wired to match the units DC input voltage specifications

(12V for PowerWalker Inverter 1000VA, 24V for PowerWalker Inverter 2000VA )

EN

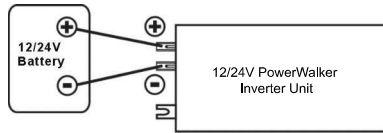

In addition, the batteries can be wired to provide additional run time. The various wiring configurations are as follows:

- Series Connection:** Wiring batteries in “series” increases the total output voltage. This voltage **MUST** match the DC voltage requirements of the PowerWalker Inverter unit, or it may damage both the PowerWalker Inverter unit and/or the batteries.

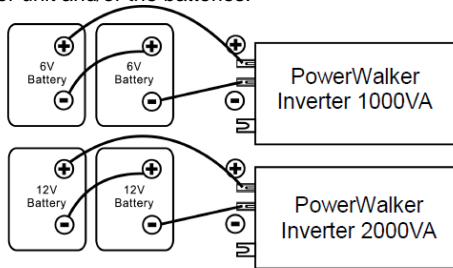

- Parallel Connection:** Wiring batteries in “parallel” increases the total run time, the batteries can operate the AC loads. The more batteries connected in parallel the longer run time the loads can be powered from the PowerWalker Inverter unit.

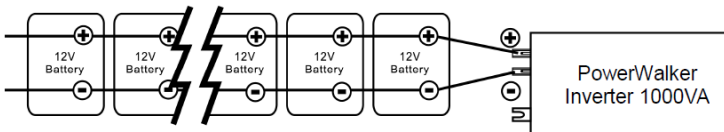

- Series-Parallel Connection:** “Series-parallel” configuration increases both the battery voltage (to match the DC requirements of PowerWalker Inverter unit) and run time for operating the AC loads.

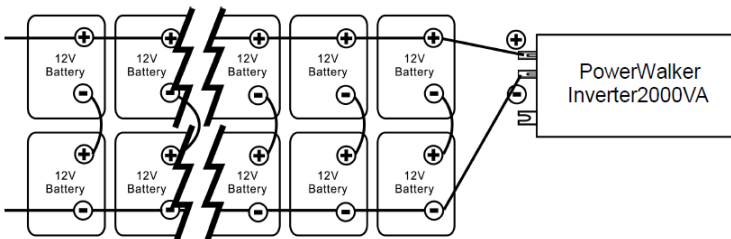

## SPECIFICATION

MODEL		PowerWalker Inverter 1000	PowerWalker Inverter 2000
CAPACITY		1000VA/600W	2000VA/1200W
AC INPUT	Nominal Voltage	220/230/240VAC	
	Input Voltage Range	90~280VAC	
	Nominal Frequency	50/60Hz (Auto Detection)	
INPUT VOLTAGE RANGE SELECTOR	Narrow	170~280VAC	
	Wide	90~280VAC	
POWERWALKER INVERTER MODE OUTPUT	Voltage	230VAC +10/-18%	
	Frequency	50/60Hz ±0.5Hz	
	Waveform	Modified Sine-wave	
	Efficiency (AC to AC)	> 95%	
	Efficiency (DC to AC)	> 80%	
BATTERY	Nominal Voltage	12V DC	24V DC
CHARGER	Charging Voltage	13.7+/-0.2V	27.4+/-0.4V
	Charging Current	10A max.	
	Overcharging Protection	16V+/-0.4V	32V+/-0.8V
TRANSFER	Transfer Time	Typical 15-20ms, 40ms max	
INDICATOR	Line Mode	Green LED blinks or lights steadily	
	Battery Mode	Yellow LED lights	
	Overload/fault	Red LED blinks or lights steadily	
AUDIBLE ALARM	Low Battery Voltage in Battery Mode	Beeps every 2 seconds	
	Overload	Beeps every 0.5 second.	
	Fault	Beeps continuously	
ENVIRONMENT	Temperature	0 ~ 40°C	
PHYSICAL	Dimension (mm) DXWXH	255x80x224	
	Net Weight (Kg)	2.3Kg	2.5Kg
PROTECTIONS	Deep Discharge, Overcharge, Short Circuit, Overload, Battery Short, Over Voltage, Under Voltage.		

## Troubleshooting

Problem	Possible Causes	Remedy
No LED display	1. Battery Weak	1. Re-charge battery
	2. Battery defective	2. Battery replacement.
	3. Power switch is not pressed	3. Press and hold power switch.
Mains normal but works in PowerWalker inverter mode	1. AC Input missing	1. Check AC input connection.
	2. Input protector is effective	2. Reset the input protector.
Alarm buzzer beeps continuously	Overload	1. Verify that the load matches the capability specified in the specs.
Back up time is shortened	Overload	1. Remove some non-critical load.
	Battery voltage is too low.	2. Charge battery for 8 hours or more.

If any abnormal situations occur that are not listed above, please call service personnel immediately.

## Appendix A

Models	Input/output cables (gauge copper wire)	Battery cables (gauge copper wire)
1000VA/12VDC	At least 18AWG	At least 8AWG
2000VA/24VDC	At least 18AWG	At least 8AWG

## Safety and EMC requirements

Safety Standard	EN60950-1
EMC Standard	EN62040-2